

GARAGE BUILDING EXTERIOR ELEVATIONS

GARAGE BUILDING EXTERIOR ELEVATIONS

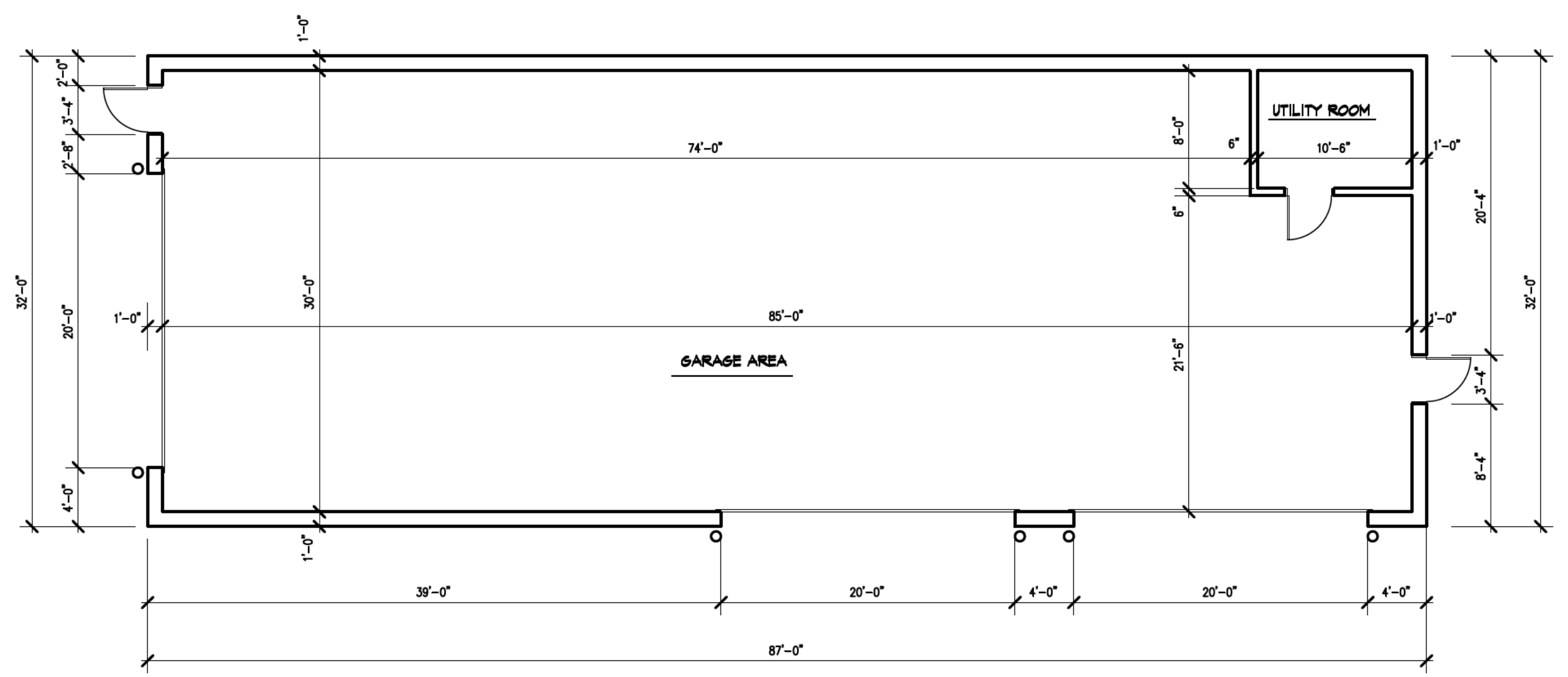

ZONING SUMMARY DATA
VILLAGE OF BOLINGBROOK, ILLINOIS

PROJECT LOCATION:
N/E CORNER OF CANTERBURY LANE AND LILY CACHE

TWO LOTS:
NORTH LOT 200 FT x 180 FT
SOUTH LOT 200 FT x 140 FT
TOTAL ACREAGE: 1.47 ACRES

ZONING DISTRICT:
B-1 LOCAL RETAIL DISTRICT

MINIMUM FRONT YARD	30 FT
MINIMUM SIDE YARD	10 FT
MINIMUM TRANSITION YARD	30 FT
FAR RATIO	35%
MAXIMUM FAR	22,400 SF
ACTUAL FAR	14,293 SF
MAXIMUM BUILDING HEIGHT	40 FT

MINIMUM PARKING SPACE
SIZE REQUIRED 9 FT x 19 FT
ACTUAL PARKING SPACE PROVIDED 9 FT x 20 FT

NUMBER OF PARKING SPACES REQUIRED:
WAREHOUSE AREA 1/1,500 SF + 4
8 REQUIRED
FOOD PANTRY 1/200 SF
10 REQUIRED
OFFICE AREAS 1/300 SF
10 REQUIRED
TOTAL SPACES REQUIRED 28
TOTAL SPACES PROVIDED 32

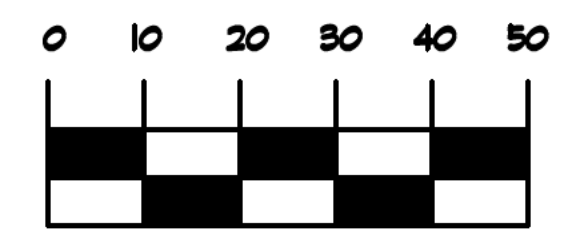
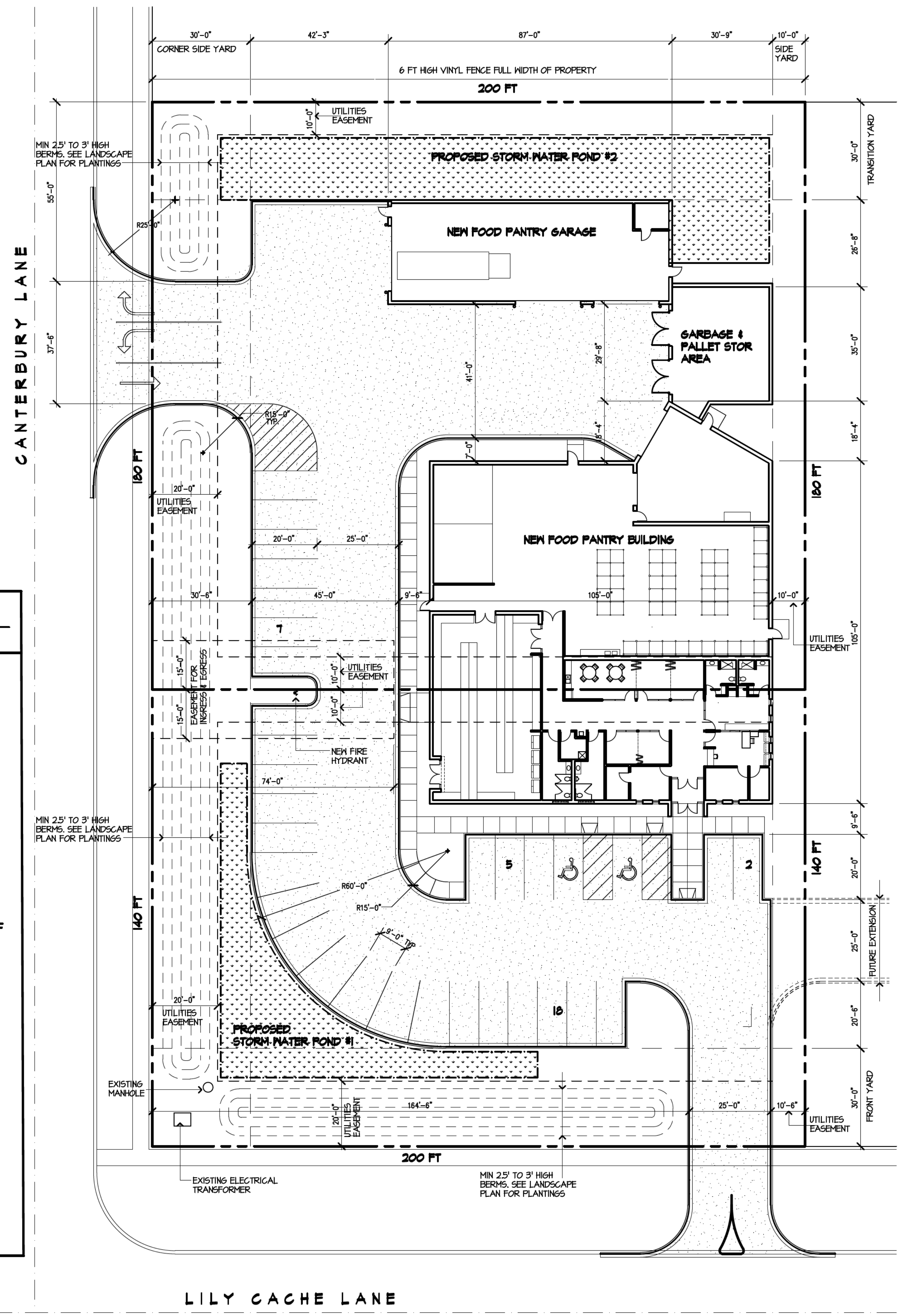

planners
CODY/BRAUN & ASSOCIATES, LLC
1882 MARNE ROAD • BOLINGBROOK, IL 60490 • 680-771-1888



SITE PLAN & GARAGE PLAN & ELEVATIONS
NEW FOOD PANTRY FACILITY FOR:
DUPAGE TOWNSHIP
241 CANTERBURY LANE, BOLINGBROOK, IL

DATE
xx/xx/xx
CAD FILE
222003SitePlan
JOB NO.
222003
DRAWN BY
JEB

SHEET
A-01
OF X

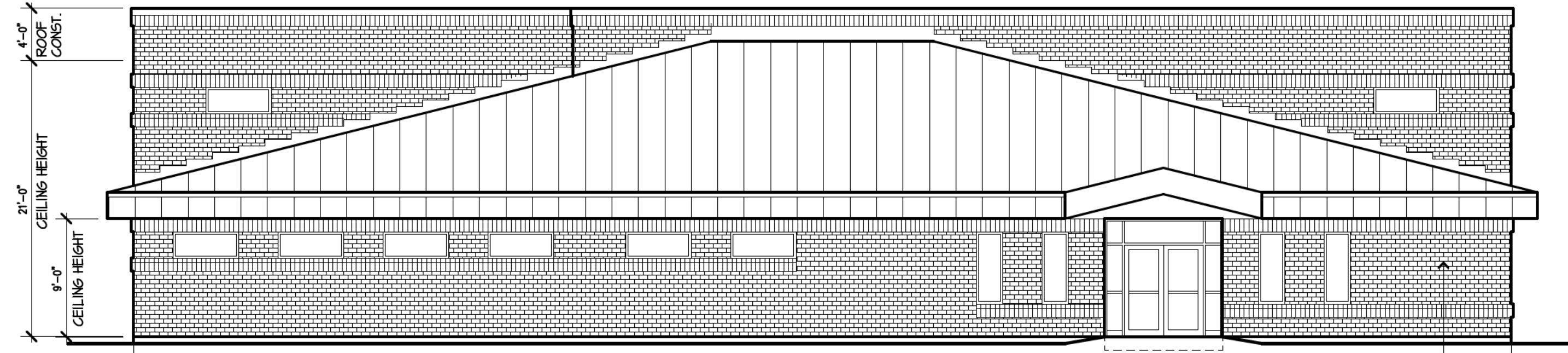
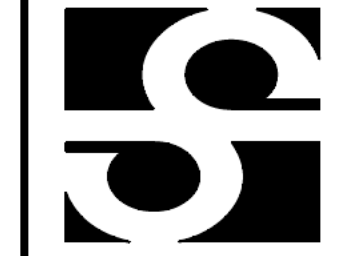

SOUTH ELEVATION
SCALE: 1/8" = 1'-0"

4" X 12" FACE BRICK

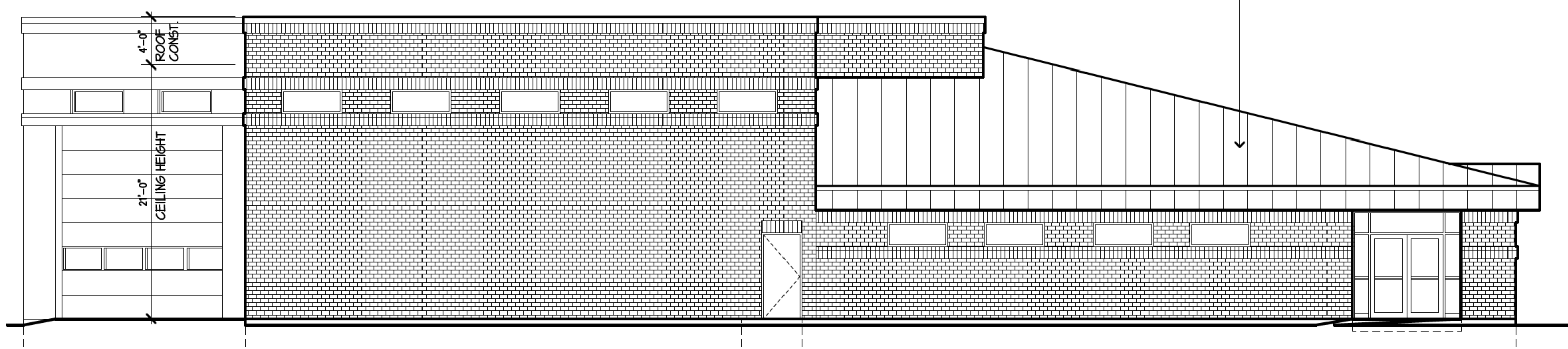

WEST ELEVATION
SCALE: 1/8" = 1'-0"

STANDING SEAM METAL ROOF

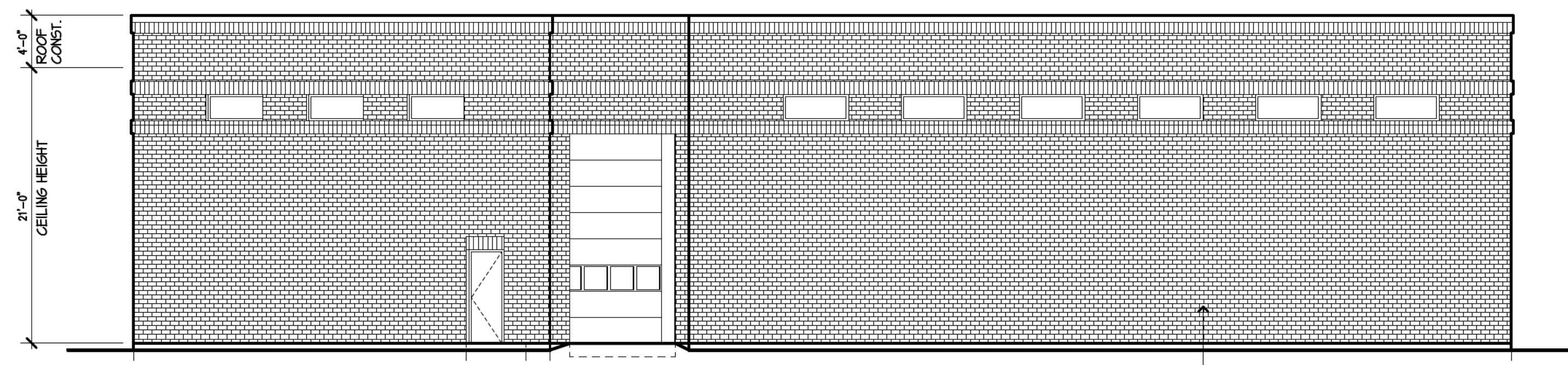

NORTH ELEVATION
SCALE: 1/8" = 1'-0"

4" X 12" FACE BRICK

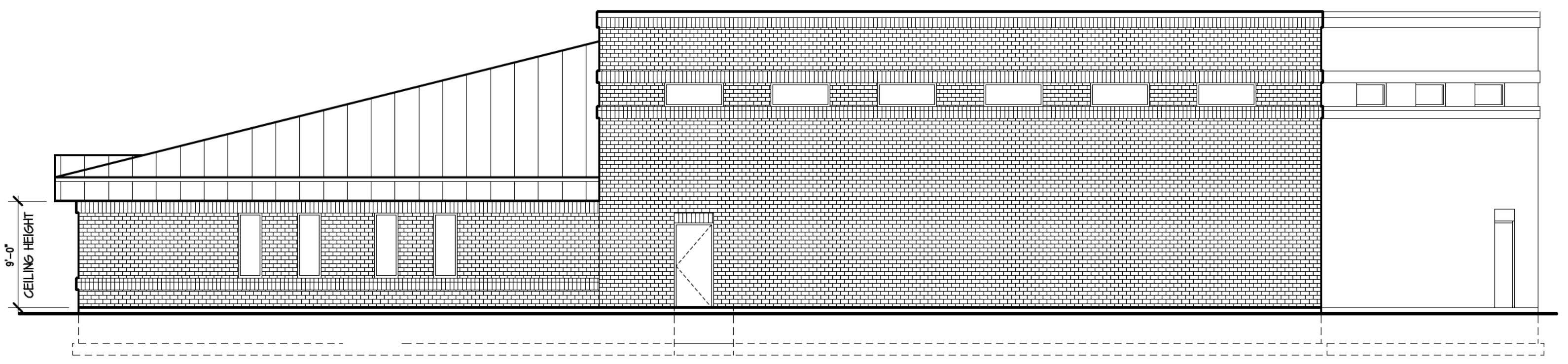

EAST ELEVATION
SCALE: 1/8" = 1'-0"

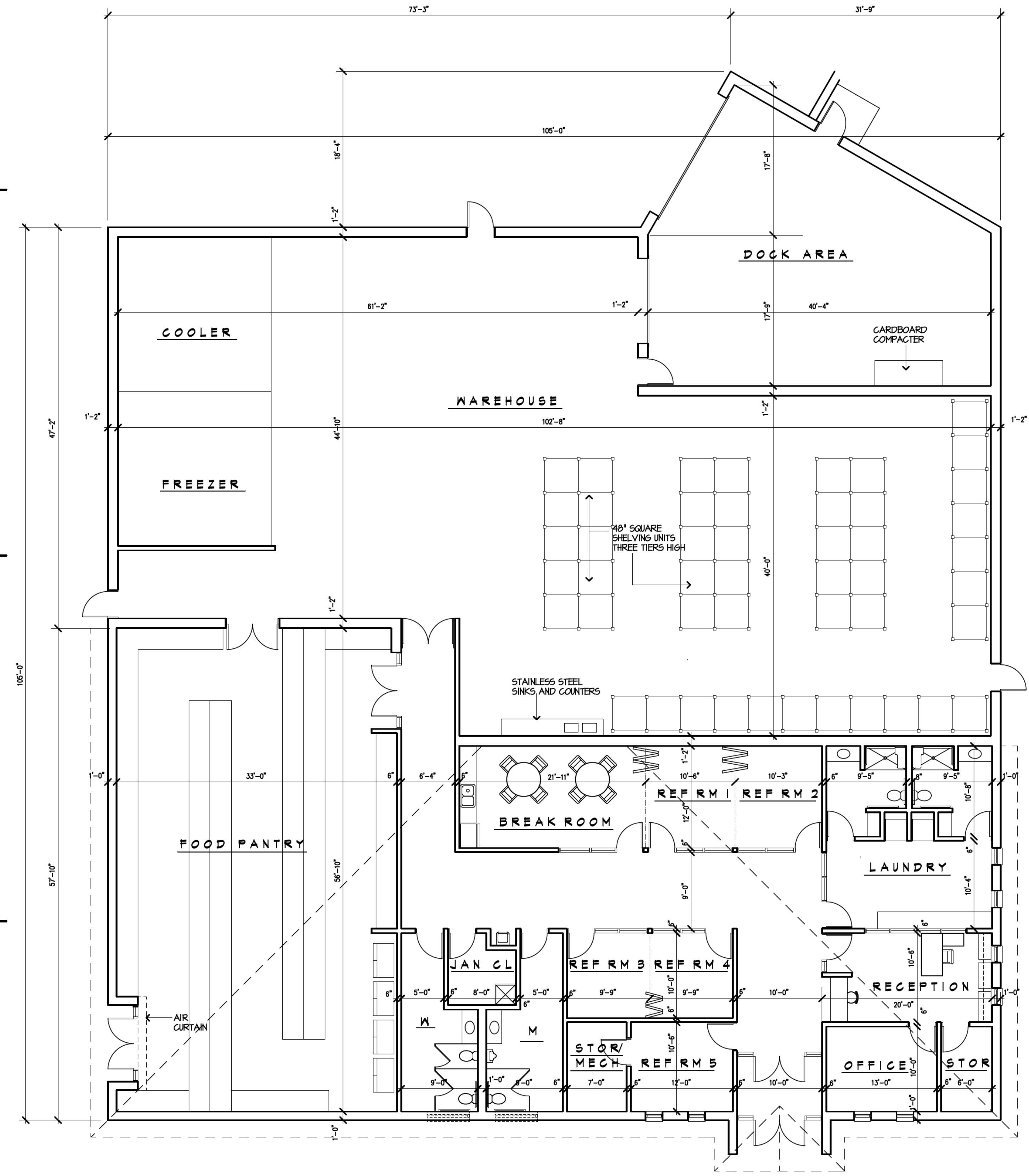

FLOOR PLAN
SCALE: 1/8" = 1'-0"



NORTH

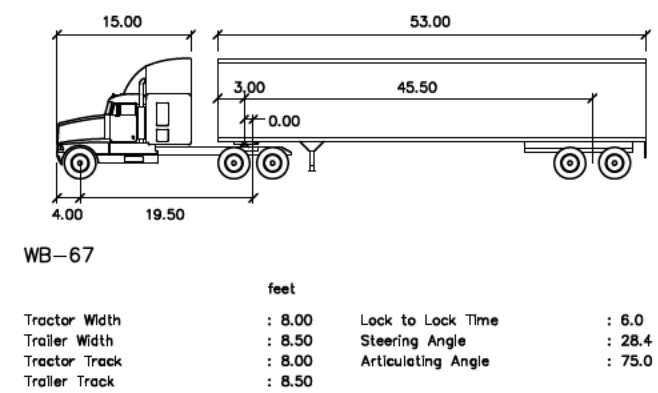
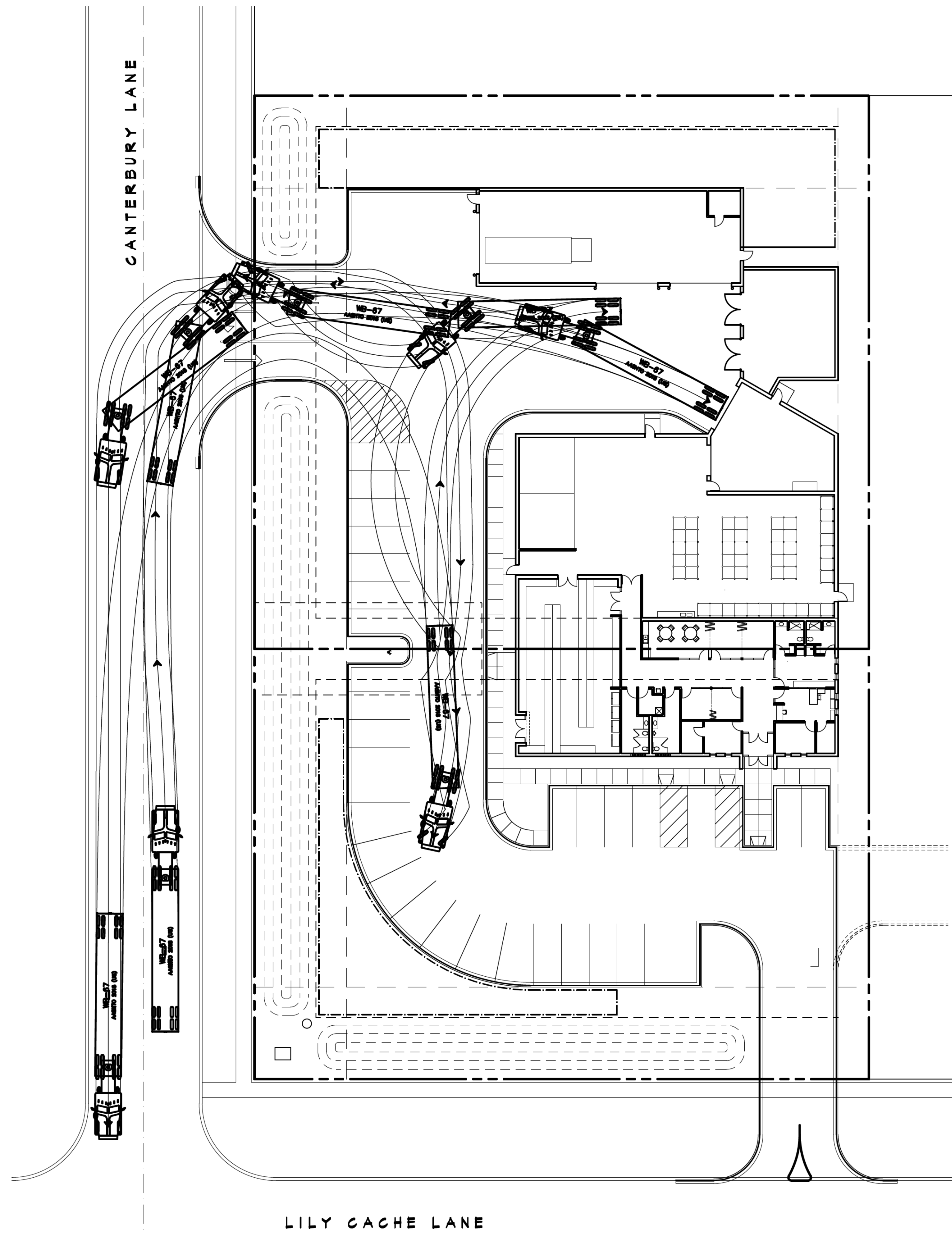

**SEMI-TRUCK ACCESS
SITE PLAN**
SCALE: 1" = 20'-0"

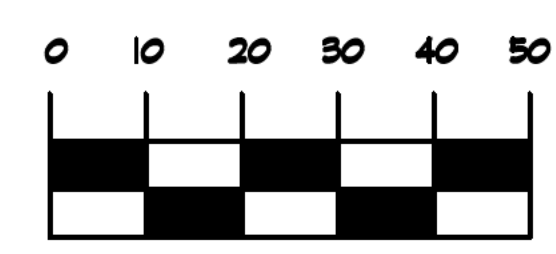

REVISIONS
JULY 14, 2023

© 2023
CODY/BRAUN & ASSOCIATES
ALL RIGHTS RESERVED

architects
CODY/BRAUN & ASSOCIATES, LLC
1822 MARNE ROAD • BOLINGBROOK, IL 60490 • 680-771-1888



SEMI-TRUCK ACCESS PLAN
NEW FOOD PANTRY FACILITY FOR:
DUPAGE TOWNSHIP
241 CANTERBURY LANE, BOLINGBROOK, IL

DATE
xx/xx/xx

CAD FILE
222003SitePlan

JOB NO.
222003

DRAWN BY
JEB

SHEET

A-03
OF **X**

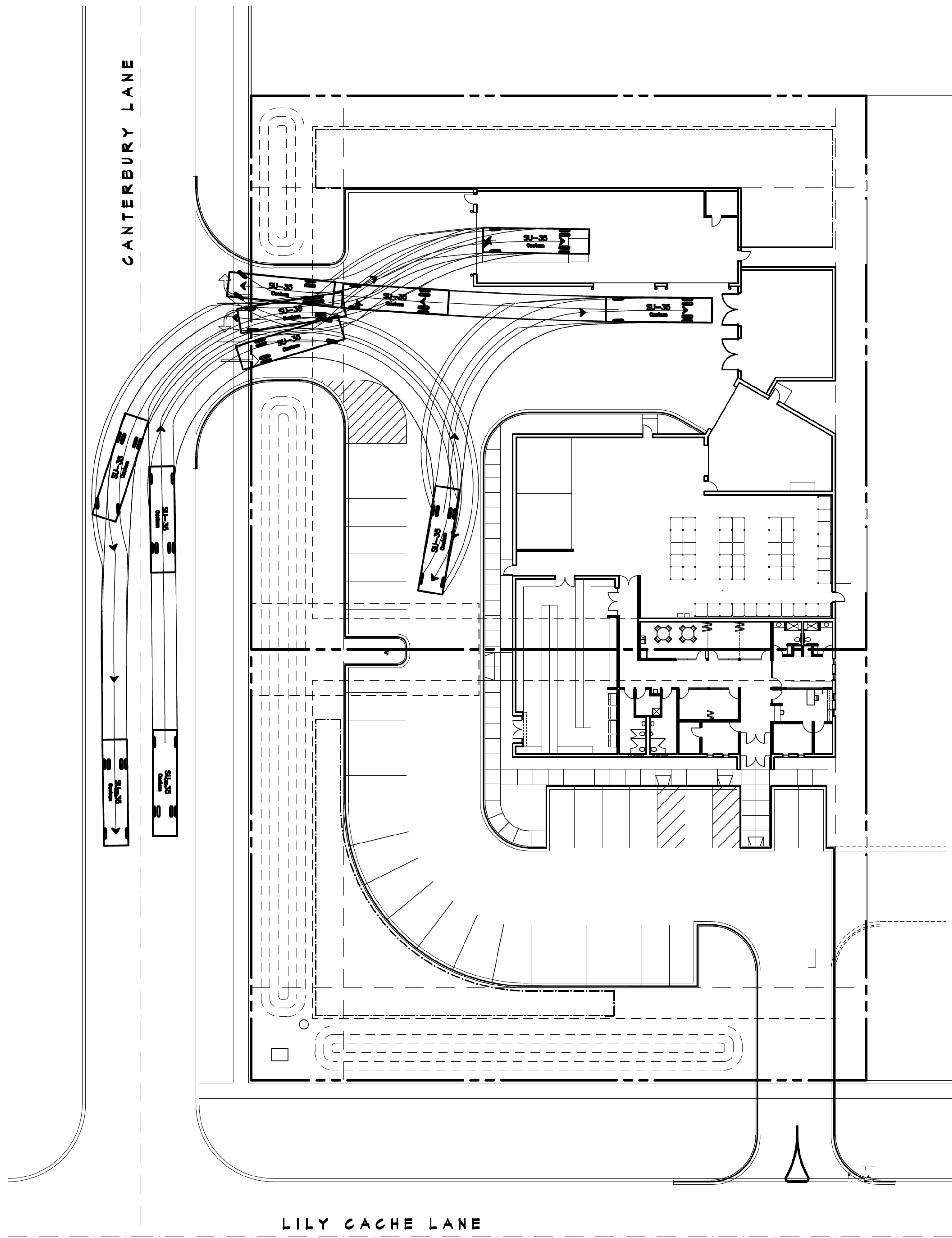

**BOX-TRUCK ACCESS
SITE PLAN**
SCALE: 1" = 20'-0"

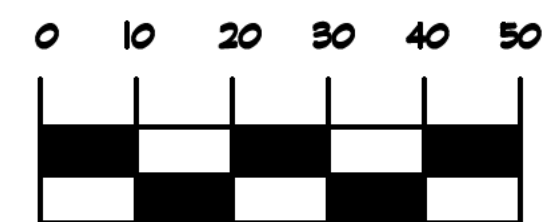

REVISIONS

JULY 14, 2023

© 2023
CODY/BRAUN & ASSOCIATES
ALL RIGHTS RESERVED

architects
CODY/BRAUN & ASSOCIATES, LLC
1888 MARNE ROAD • BOLINGBROOK, IL 60490 • 680-771-1888



BOX-TRUCK ACCESS PLAN

NEW FOOD PANTRY FACILITY FOR:

DUPAGE TOWNSHIP

241 CANTERBURY LANE, BOLINGBROOK, IL

DATE

xx/xx/xx

CAD FILE

222003SitePlan

JOB NO.

222003

DRAWN BY

JEB

SHEET

A-04

OF X



June 27, 2023

VIA EMAIL

DTAdministrator@dupagetownship.com

Ms. Jackie Traynere
Administrator
DuPage Township
241 Canterbury Lane
Bolingbrook, Illinois 60440

Re: *Food Pantry Facility*
Lily Cache Lane and Canterbury Lane
Bolingbrook, Illinois

Dear Ms. Traynere:

We at BLA-Inc appreciate the opportunity to provide this professional engineering services proposal for the above-referenced project. Pursuant to your request, we are submitting this professional services proposal for work on the above-referenced site. Following is a brief scope of work and the associated fee. We are available immediately to discuss specific details and scheduling requirements. We understand that timing is critical on this work, and we will make every effort to complete this work in as timely a manner as possible. We will commence with the following scope of work upon your notice to proceed and authorization.

TRANSPORTATION ENGINEERING SCOPE OF WORK AND FEES

BLA will provide transportation planning and engineering services for the proposed food pantry development located on the northeast corner of Lily Cache Lane and Canterbury Lane in Bolingbrook, Illinois. The approximately 1.47-acre site is currently vacant.

As currently proposed, the project includes developing the site to provide an approximately 11,650 square-foot food pantry building, including supporting warehouse and office space, and an approximately 2,650 square-foot food pantry storage garage. The facility will be served by a total of 16 employees (3 full time and 13 part time). The proposed facility will replace the existing food pantry located at 719 Parkwood Avenue in Romeoville. Access to the site is proposed via a new full access driveway on Canterbury Lane and a right-in/right-out only driveway on Lily Cache Lane. Canterbury Lane and Lily Cache Lane are both under local, Village of Bolingbrook jurisdiction.

Our work will include the preparation of a Traffic Impact Study in accordance with the Village of Bolingbrook standards, including all necessary exhibits. It will also include coordination with the project team, the Village of Bolingbrook, as necessary.

T.01 – Traffic Impact Study

1. Collect existing available data related to the site and surrounding area, including available recent traffic counts conducted along surrounding roadways, intersection and roadway plans and perform general observations in the site vicinity pertaining to traffic. *BLA will also obtain from the Client anticipated operational characteristics of the proposed facility (i.e., hours of operation, number of employees, number of families served on a typical day, delivery frequency, size of delivery vehicle, etc.).*
2. Conduct 24-hour weekday (Tuesday, Wednesday or Thursday) traffic counts at the intersection of Lily Cache Lane and Canterbury Lane.

3. Obtain daily traffic counts along the study area roadways from IDOT’s website: www.gettingaroundillinois.com.
4. Obtain from the IDOT Division of Safety crash reports for the most recent five (5) years within the study area to determine the current level of operation / safety issues.
5. Develop a future year, no-build, traffic volume network that includes existing traffic and any anticipated background growth and roadway improvement projects within the study area. BLA will obtain future 2050 traffic volume projections from the Chicago Metropolitan Agency for Planning (CMAP).
6. BLA will estimate the number of trips in connection with the proposed development. We will reference published rates contained in the ITE Trip Generation Handbook, local information provided by the Client and/or other approved sources, as applicable. Directional distribution of the traffic approaching and departing the site will be determined from the existing data available and the proposed site access plan. *We will confirm the development assumptions – land use, size and site access prior to completion of this task.*
7. Conduct intersection capacity analyses during the weekday am (7:00 to 9:00 AM) and weekday pm (4:00 to 6:00 PM) peak hours at the study intersections under existing and future traffic conditions. *This will include a summary of the existing and future operations of the southbound left-turn movement from Canterbury Lane onto eastbound Lily Cash Lane (one of the Village’s concerns).*
8. BLA will make recommendations, if necessary, for any improvements to accommodate existing and future traffic volumes, such as intersection traffic control, signing and/or access modifications.
9. A general review of the site plan components will be performed, including the adequacy of circulation and loadings in accordance with Village of Bolingbrook requirements. Recommendations will be provided to improve operations, if necessary. BLA will perform an Auto Turn analysis to ensure the design vehicle can adequately access/circulate the site loading areas. *This will address one of the other Village’s concerns pertaining to the ability for trucks to access the truck dock.*
10. Prepare a Traffic Impact Study including supporting exhibits, to help explain the findings. The report will be appropriate for submittal to the Village of Bolingbrook.

BLA is prepared to commence work upon receipt of written authorization to proceed. Traffic data collection and observations can typically be completed within 7 to 10 days of authorization to proceed and our draft traffic study, including preliminary findings, can be ready for review 3 to 4 weeks after authorization to proceed. *BLA staff is committed to working with the Client to adjust the project schedule to meet its submission deadlines, as appropriate.*

Traffic Impact Study (Tasks 1 and 3 to 10) shall be performed for a lump sum fee of.....	\$4,700.00
<u>Traffic Counts (Task 2)</u>	<u>\$1,750.00</u>
<u>Total (Tasks 1-10)</u>	<u>\$6,450.00</u>

T.02 – Meetings and Hearings

BLA staff are available to attend and testify at Village Commissions, Committees or Boards, as well as project team meetings, as requested. *For this scope, meetings are not included and would be considered an additional service to be performed at your direction.*

Any items not specifically included in the above scope of services (i.e., additional traffic data collection or analysis, revisions to the study resulting from changes in the site plan, project density or access modifications, responding to Village comments, etc.) will be considered extra work to be performed at your direction.

Our fees for professional services are listed below.

Principal.....	\$250.00
Director of Structural Engineering.....	\$215.00
Director of Construction Engineering.....	\$215.00
Director of Preliminary Design Services.....	\$215.00
Assistant Director of Structural Engineering.....	\$200.00
Senior Transportation Engineer.....	\$185.00
Director of Municipal Services.....	\$160.00
Senior Project Manager.....	\$160.00
Director of Environmental Services.....	\$150.00
Project Manager.....	\$130.00
Project Engineer.....	\$100.00
Structural Engineer II.....	\$95.00
Structural Engineer I.....	\$90.00
Design Engineer.....	\$85.00
Senior Resident Engineer.....	\$175.00
Resident Engineer II.....	\$140.00
Resident Engineer I.....	\$110.00
Construction Engineer II.....	\$95.00
Construction Engineer I.....	\$85.00
Documentation Engineer.....	\$100.00
Public Outreach Coordinator.....	\$80.00
Clerical Assistance.....	\$60.00
Project Surveyor (PLS).....	\$150.00
Vehicle (per day).....	\$65.00
Vehicle (half-day).....	\$32.50
Reimbursable Expenses/Direct Costs.....	as incurred (pass through, no markup)

Invoices will be mailed out monthly. Payment is to be made within thirty days after receipt of our invoice.

Client understands and agrees that on January 1, 2024, and yearly thereafter, the fees and quotes for services to be performed shall be increased by an amount not to exceed 5%.

Please let us know if any of the above information is at variance with your instructions. If this correctly reflects your instructions and is acceptable, please sign below and return one copy for our file.

Thank you for requesting BLA, Inc. to do this work.

Should you have any questions or require additional information please contact us at (630) 438-6400.

Sincerely,

BLA-Inc.

Lynn M. Means

Lynn M. Means, P.E., PTOE, RSP1
Senior Transportation Engineer

ACCEPTANCE:

DUPAGE TOWNSHIP

BY:



TITLE:

SUPERVISOR

DATE:

6/28/23



DuPage Township

241 Canterbury Ln. Bolingbrook, IL 60440

staff@dupagetownship.com fax 630-759-3412

DuPage Township, Liaison or Committee Appointment Request

Name: Cassandra Davis

Phone number: [REDACTED]

Address: [REDACTED]

City: Bolingbrook

Zip: 60440

Email address: [REDACTED]

The DuPage Township Board of Trustees appreciates your interest in serving our

community. In order to assist the Township Board in assessing your qualifications and interests please answer the following questions by typing or legibly printing your response. Those interested must complete and sign this form to be nominated, appointed, re-appointed or officially authorized to serve. Please read through the attached information prior to completing this request (additional sheets may be attached if necessary). Although there are a limited number of official committee or liaison positions available, even those not appointed to a specific position are always welcome to attend committee meetings, provide their ideas, and volunteer at township-sponsored events.

1. Are you a resident of DuPage Township? YES NO
2. Are you applying for a: Committee Position Liaison Position
3. Are you currently, or have you previously served on a DuPage Township; Village of Bolingbrook; Village of Romeoville; City of Naperville; other municipal, county or government sponsored committee? If yes, Please explain:

I am not currently serving on another board.

4. Do you have any experience, education, or background that would assist or contribute to serving in any position on a voluntary capacity?

Yes

5. Please indicate which areas you have an interest in assisting: Youth Services Committee

Senior Citizen Committee

6. Do you have any relationship or reason that might possibly constitute a conflict of interest if you are selected to serve/represent the Township in any capacity? If yes, please explain:
No

I have completed the application to the best of my ability, acknowledge that all information above is true and accurate to the best of my knowledge. I have read the attached guidelines and eligibility information and understand that this application does not guarantee my appointment. I agree to complete any additional forms and

[Redacted Signature]

06/25/2023

Date

General Membership Information:

- Committee and Liaison Members serve at the pleasure of the Township Board and may be removed from the position or service at any time for such cause as the Township Board sees fit.
- Attendance at monthly committee meetings is necessary. Any committee member absent for more than two consecutive committee meetings without notifying the chairperson shall be subject to removal from the committee by action of the Township Board.
- The primary function of membership of the standing committees and liaison positions is to investigate concerns arising in their respective areas of interest; to promote the best interests of the Township; to recommend policies, procedures, and actions for board consideration.
- Committee or Liaison appointments and participation therein shall be subject to and in compliance with the Open Meetings Act, Freedom of Information Act, Gift Ban Act, Ethics Law, and any other State and Federal Laws and mandates.
- Members may be required to complete on-line training as well as statements of economic interest in compliance with the aforementioned acts and laws. Failure to complete any required forms or trainings within 90 days of notification by chairperson may result in removal from the committee by action of the Township Board.

For Office Use Only

Request Received Date *J* *j* Received By: _____

Proof of Residency provided? _____ Verified By: _____



DuPage Township

241 Canterbury Ln. Bolingbrook, IL 60440

staff@dupagetownship.com fax 630-759-3412

DuPage Township, Liaison or Committee Appointment Request

Name: Diane Iteu Phone number: [REDACTED]

Address: [REDACTED]

City: Bolingbrook Zip: 60440 Email address: [REDACTED]

The DuPage Township Board of Trustees appreciates your interest in serving our community. In order to assist the Township Board in assessing your qualifications and interests please answer the following questions by typing or legibly printing your response. Those interested must complete and sign this form to be nominated, appointed, re-appointed or officially authorized to serve. Please read through the attached information prior to completing this request (additional sheets may be attached if necessary). Although there are a limited number of official committee or liaison positions available, even those not appointed to a specific position are always welcome to attend committee meetings, provide their ideas, and volunteer at township-sponsored events.

1. Are you a resident of DuPage Township? YES NO
2. Are you applying for a: Committee Position Liaison Position
3. Are you currently, or have you previously served on a DuPage Township; Village of Bolingbrook; Village or Romeoville; City of Naperville; other municipal, county or government sponsored committee? If yes, Please explain:

Original Senior Committee

4. Do you have any experience, education, or background that would assist or contribute to serving in any position on a voluntary capacity?

5. Please indicate which areas you have an interest in assisting:

Youth Services Committee

Senior Citizen Committee

6. Do you have any relationship or reason that might possibly constitute a conflict of interest if you are selected to serve/represent the Township in any capacity? If yes, please explain:

NO

I have completed the application to the best of my ability, acknowledge that all information above is true and accurate to the best of my knowledge. I have read the attached guidelines and eligibility information and understand that this application does not guarantee my appointment. I agree to complete any additional forms and training shall I be appointed to serve.

Applicant's Signature

6/27/23
Date

General Membership Information:

- Committee and Liaison Members serve at the pleasure of the Township Board and may be removed from the position or service at any time for such cause as the Township Board sees fit.
- Attendance at monthly committee meetings is necessary. Any committee member absent for more than two consecutive committee meetings without notifying the chairperson shall be subject to removal from the committee by action of the Township Board.
- The primary function of membership of the standing committees and liaison positions is to investigate concerns arising in their respective areas of interest; to promote the best interests of the Township; to recommend policies, procedures, and actions for board consideration.
- Committee or Liaison appointments and participation therein shall be subject to and in compliance with the Open Meetings Act, Freedom of Information Act, Gift Ban Act, Ethics Law, and any other State and Federal Laws and mandates.
- Members may be required to complete on-line training as well as statements of economic interest in compliance with the aforementioned acts and laws. Failure to complete any required forms or trainings within 90 days of notification by chairperson may result in removal from the committee by action of the Township Board.

For Office Use On

Request Received Date 7/12/2023 Received By 

Proof of Residency provided? NO Verified By: J. J.

NOT AVAILABLE
FOR TWO MONTHS

Oscar Painting & Remodeling LLC
.631 Montrose Drive
Romeoville, Illinois 60446
United States

Mobile: 630-854-0494

Estimate

BILL TO
Bob
Bob Martin
241 Canterbury Ln.
bolingbrook, Illinois 60440
United States

rm7@aol.com

Estimate Number: 238

Estimate Date: July 10, 2023

Expires On: September 30, 2023

Grand Total (USD): \$3,800.00

Items	Quantity	Price	Amount
exterior paint sand the iron bridge and paint one coat of primer and tow of semigloss black protect wood floor	1	\$3,800.00	\$3,800.00

GENERAL CONDITIONS OF SALE

1. PRICE QUOTES:

The price quoted assumes a clear and level site with normal soil/building conditions. If in the prosecution of the work under this Contract, Oscar Painting Company encounters unusual soil or water conditions, buried utility lines, obstructions, inaccurate surveys or descriptions or any other factors that affect the price quoted or time for completion, Oscar Painting Company will notify the Customer of such factors and the price set forth in this Agreement, shall be adjusted to compensate Oscar Painting Company, accordingly.

Oscar Painting & Remodeling LLC
.631 Montrose Drive
Romeoville, Illinois 60446
United States

Mobile: 630-854-0494

Estimate

Items	Quantity	Price	Amount
GENERAL CONDITIONS OF SALE #2 2. WRITING: No terms, conditions or representations altering, detracting from, or adding to the terms hereof, shall be valid unless evidenced in writing and signed by Oscar Painting Company, The Customer and Oscar Painting Company agree that this proposal as accepted constitutes the entire agreement between the parties, and that no oral representation or agreement has been made which would modify this agreement or be a condition precedent or subsequent to the enforcement of this agreement and may not be modified except in writing signed by each of the parties	1	\$0.00	\$0.00
GENERAL CONDITIONS OF SALE#3 3. Traffic Control: The Customer is responsible for obtaining all necessary jobsite permits, providing traffic control and all required jobsite equipment/accessories(Flagmen, barricades, lightning, reflectors, etc.), throughout the course of each and every delivery, set, and pick-up. Should the Customer fail to provide traffic control on any given day, Oscar Painting Company may or may not elect to proceed with their current schedule until the proper traffic control is available, if this situation occurs; Oscar Painting Company will not be accountable for the delayment of delivery, pick-up, or the agreement time in the proposal.	1	\$0.00	\$0.00
PAYMENT Accept Credit Card Payments: Visa, MasterCard, Discovery	1	\$0.00	\$0.00

Oscar Painting & Remodeling LLC
.631 Montrose Drive
Romeoville, Illinois 60446
United States

Mobile: 630-854-0494

Estimate

Items	Quantity	Price	Amount
PAYMENT TO BE MADE AS FOLLOWS 50% up front and 50% upon final installation.	1	\$0.00	\$0.00
I Hereby Acknowledge the satisfactory completion of the above described work. Customer's Signature:	1	\$0.00	\$0.00
Date:			
		Total:	\$3,800.00
		Grand Total (USD):	\$3,800.00

CURRENT

High Quality Painting LLC.

Licensed/insured
773-316-9059
garcia7213@sbcglobal.net
334 Lancelot ct. Bolingbrook Il, 60440

THIS AGREEMENT made the day: 7/11/2023

By and between high quality painting LLC. hereinafter called the contractor and hereinafter called the owner.

WITNEEETH that high quality painting and. Robert Martin

that work will be performed on the property at: 251 canterbury ln, Bolingbrook il,

The work includes all, labor and equipment for:

DESCRIPTION	PRICE
Pel of bridge metal, reprime and two coats of epoxy paint	3800.00

All work done for high quality painting are guarantee for two years.

the homeowner shall pay to high quality painting for the materials and labor to be performed under the contract the sum of: _____

_____. subject to additions and deductions pursuant authorized change orders

High quality painting reserves the right to file and place a mechanics or property lien to any costumer that has not paid for services received with thirty days after completing of work.

High quality painting deems the right to add all lien collections cost to any unpaid invoice thirty days past due. final payment will be given when the job is fully completed.

The work to be performed under this contract shall be commenced by _____ and completed by _____

signature _____

signature _____



Live Painting CORP.
CONSTRUCTION PAINTING

current

Live Painting Corporation

554 Anderson Drive | Romeoville, Illinois 60446
6309953936 | LivePainting@Live.com | LivePaintingCorp.com

RECIPIENT:

Bob

215 Canterbury Lane
Bolingbrook, Illinois 60440

Phone: 8153024898

Quote #494

Sent on

Jun 27, 2023

Total

\$4,500.00

PRODUCT / SERVICE	DESCRIPTION	QTY.	UNIT PRICE	TOTAL
EXTERIOR PAINTING	<p>Before paint:</p> <p>Scraping, sanding remove all old paint, sanding, clean 2 coats primer & 2 coats paint.</p> <p>RAILING: 1 COAT PRIMER & 2 COATS PAINT</p> <p>PREPARATION IS A KEY TO SUCCESSFUL LONG LASTING FINISH! WE TAKE PRIDE IN OUR WORK!</p>	1	\$3,550.00	\$3,550.00
EXTERIOR MATERIALS	<p>Sherwin Williams Paints & Materials</p> <p>Sherwin Williams: PRO Industrial Exterior Paints.</p> <p>This is the Price included high quality work and paint!</p>	1	\$950.00	\$950.00

Total

\$4,500.00

This quote is valid for the next 30 days, after which values may be subject to change.

High Quality Painting LLC.

Licensed/insured
773-316-9059
garcia7213@sbcglobal.net
334 Lancelot ct. Bolingbrook Il, 60440

THIS AGREEMENT made the day: 7/14/2023

By and between high quality painting LLC. hereinafter called the contractor and hereinafter called the owner.

WITNEESETH that high quality painting and. Robert Martin

that work will be performed on the property at: 251 canterbury ln, Bolingbrook il,

The work includes all, labor and equipment for:

DESCRIPTON	PRICE
Pel of bridge metal, reprime and two coats of epoxy paint	3800.00

All work done for high quality painting are guarantee for two years.

the homeowner shall pay to high quality painting for the materials and labor to be performed under the contract the sum of: _____

_____ . subject to additions and deductions pursuant authorized change orders

High quality painting reserves the right to file and place a mechanics or property lien to any costumer that has not paid for services received with thirty days after completing of work.

High quality painting deems the right to add all lien collections cost to any unpaid invoice thirty days past due. final payment will be given when the job is fully completed.

The work to be performed under this contract shall be commenced by _____ and completed by _____

signature _____

signature _____

DIESEL SERVICE CENTER

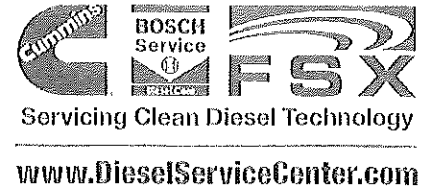

1 Seidel Court • Bolingbrook, IL 60490 • 815.306.6050

I N V O I C E

JULY 10, 2023

INVOICE #: D070072

BILL TO: 004285
DUPAGE TOWNSHIP
241 CANTERBURY LANE
BOLINGBROOK, IL 60440

SHIP TO:

* SAME *

PHONE: 630/759-1317

SHIP VIA: WILL CALL

SERVICE TYPE	COLOR	LIC#	UNIT#	CPL INJ
OIL LEAK	WHITE	M188416	IL	
VIN#	YR-MAKE.....	VEH MODEL.....	ENGINE	MILES/HOURS
1HTSCABM6YH235976	IHC		444	243100

CHANGE REAR MAIN SEAL

R&R MAIN REAR SEAL
R&R REAR COVER

1,446.90
289.38

REMOVED DRIVE SHAFT. REMOVED ALL ELECTRICAL CONNECTIONS AND TRANS COOLING LINES. DRAINED TRANSMISSION INTO CLEAN BUCKET, REUSED THE TRANS OIL. REMOVED THE TRANS, REMOVED BELL HOUSING, FLYWHEEL AND REAR ENGINE COVER. R&R REAR MAIN SEAL. CLEANED AND RESEALED THE BLOCK AND REPLACED REAR ENGINE BLOCK COVER. RE INSTALLED ALL OF THE ABOVE. TEST DROVE AFTER REFILLING THE TRANSMISSION. STILL LEAKING FROM REAR OF ENGINE.

ATTEMPTED TO RESEAL OIL PAN TO STOP LEAKING. REMOVED OIL PAN BOLT RAISED ENGINE AND REMOVED FRONT MOTOR MOUNT. REMOVED OIL PAN AND CLEANED OF ALL OLD SEALANT. APPLIED NEW SEALANT AND REINSTALLED OIL PAN. REINSTALLED FRONT MOTOR MOUNT AND TORQUED TO SPEC. INSTALLED NEW COOLANT FILTER, REFILLED COOLANT AND FILLED OIL. RAN ENGINE TO CHECK FOR LEAKS, NONE FOUND. ROAD TESTED TO VERIFY LEAK WAS REPAIRED. SFTER ROAD TEST, FOUND LEAK AT REAR OF OIL PAN

CONTINUED ON NEXT PAGE



DIESEL SERVICE CENTER

1 Seidel Court • Bolingbrook, IL 60490 • 815.306.6050



Servicing Clean Diesel Technology

www.DieselServiceCenter.com

I N V O I C E

JULY 10, 2023

INVOICE #: D070072

BILL TO: 004285
 DUPAGE TOWNSHIP
 241 CANTERBURY LANE

SHIP TO:
 * SAME *

BOLINGBROOK, IL 60440

PHONE: 630/759-1317

SHIP VIA: WILL CALL

SERVICE TYPE	COLOR	LIC#	UNIT#	CPL INJ
OIL LEAK	WHITE	M188416 IL		
VIN#	YR-MAKE.....	VEH MODEL.....	ENGINE	MILES/HOURS
1HTSCABM6YH235976	IHC		444	243100

SERVICE DESCRIPTION	AMOUNT
(GWILL) GOODWILL LABOR	N/C

PART NUMBER	PARTS DESCRIPTION	QUANTITY	LIST PRICE	UNIT PRICE	TOTAL AMOUNT
REAR MAIN SEAL		1	495.00	417.00	417.00
1818254C2	REAR ENGINE COVER	1	193.81	152.70	152.70
PMX 24200	BLUE THREADLOCKER	1	11.06	8.72	8.72
MED 3M7447	SCOTCHBRITE PAD	1	3.67	2.89	2.89
1830856C1KK	GASKET LIQUID	1	83.99	70.75	70.75

***** JOB SUMMARY *****

LABOR	1,736.28
PART SALES	652.06
SHOP SUPPLIES	69.45

NET 30 DAYS

I N V O I C E T O T A L ...\$2,457.79

ACCEPTED BY: X

Quality and Superior Customer Service is our GOAL
 For SDG Terms & Conditions visit SeidelDieselGroup.com



Dave Locke

From: Administrator
Sent: Friday, June 23, 2023 12:19 PM
To: Dave Locke; Gary Marschke
Cc: Administrator
Subject: RE: QUOTE

Yes, per Gary via phone

Sent from my Verizon, Samsung Galaxy smartphone
Jackie Traynere DuPage Township Administrator
630-759-1317 x208

----- Original message -----

From: Dave Locke <dlocke@dupagetownship.com>
Date: 6/23/23 12:15 PM (GMT-06:00)
To: Gary Marschke <gmarschke@dupagetownship.com>
Cc: Administrator <DTAdministrator@dupagetownship.com>
Subject: FW: QUOTE

Please see the below note and accompanying pictures from Diesel Services about the International truck. They need to know if we want the repair to be made while they have the everything disassembled. Please advise,

David Locke
Manager
DuPage Township Food Pantry
719 Parkwood
Romeoville IL 60446

From: Mike Green <mike@dieselservicecenter.com>
Sent: Friday, June 23, 2023 12:06 PM
To: Dave Locke <dlocke@dupagetownship.com>
Subject: RE: QUOTE

DAVE

WE WERE UNABLE TO SEE THIS REAR COVER UNTIL WE TOOK OUT TRANSMISSION. WE DISCOVERED THAT THE REAR COVER IS LEAKING TOO. THIS COVER SHOULD BE TAKEN CARE OF WHILE WE HAVE EVERYTHING ELSE DISASSEMBLED. THIS REPAIR ONLY ADDS \$453.65 TO PREVIOUS QUOTE OF \$2585.43. I ATTACHED PHOTO SO YOU CAN SEE FOR YOURSELF. THERE IS OIL EVERYWHERE! THE SEAL IS THE CIRCLE WITH FIVE HOLES IN

IT, THAT IS WHAT WE ARE ALREADY WORKING ON. THE COVER IS THE BELL SHAPED PLATE WITH THE 8 BOLTS IN IT. I HAVE THE PART ORDERED, SHOULD BE HERE BY MONDAY. DO I HAVE YOUR APPROVAL TO ADDRESS THE COVER?

THANK YOU

Mike Green

815.886.9900 x6062

815.905.1793 DIRECT

DIESEL SERVICE CENTER



From: Dave Locke <dlocke@dupagetownship.com>

Sent: Thursday, June 22, 2023 1:15 PM

To: Mike Green <mike@dieselservicecenter.com>

Subject: RE: QUOTE

Sounds good, thank you.

David Locke

Manager

DuPage Township Food Pantry

719 Parkwood

Romeoville IL 60446

From: Mike Green <mike@dieselservicecenter.com>

Sent: Thursday, June 22, 2023 1:14 PM

To: Dave Locke <dlocke@dupagetownship.com>

Subject: RE: QUOTE

Looks like tomorrow, possibly Monday, truck will be done. I will call you tomorrow

Mike Green

815.886.9900 x6062

815.905.1793 DIRECT

DIESEL SERVICE CENTER



From: Dave Locke <dlocke@dupagetownship.com>

Sent: Thursday, June 22, 2023 11:22 AM

To: Mike Green <mike@dieselservicecenter.com>

Subject: RE: QUOTE

payables

From: Dave Locke
Sent: Monday, July 10, 2023 12:55 PM
To: payables
Cc: Administrator
Subject: Diesel Service Center for the International
Attachments: 20230710123727450.pdf; 20230710125424998.pdf

Attached is the final invoice for the repairs made to the International that we picked up today. As noted on the invoice while the leak has been repaired to the extent they can, it will still leak. They suspect it may be a crack in the block which is not good. In speaking with Mike Green at Diesel, the truck can still be used locally. He suggested still using the cardboard underneath as well as monitoring the oil at least a few times a week. It will leak and he wants us to be aware of that, but they did what they could to try and mitigate the amount. At this point we will just use it as a back up and continue to monitor the levels.

David Locke
Manager
DuPage Township Food Pantry
719 Parkwood
Romeoville IL 60446

WIESBROOK SHEET METAL, INC.

25502 W. Ruff Street • Plainfield, IL 60585
Phone 630-922-9050 • Fax 630-922-9055

PROPOSAL AND AGREEMENT

Name DUPAGE TOWNSHIP Date 6/28/23
 Street Address 241 CANTERBURY City BOILING BROOK Zip Code _____
 Email Address _____ Phone # _____ Alt # _____

We will furnish and install the equipment listed below at the price, terms and conditions outlined below.

Equipment Specifications

- | | | |
|-------------------------------------|---|--|
| <input type="checkbox"/> | Condenser Option 1 | Price \$ _____ |
| <input type="checkbox"/> | Furnace Option 1 | Price \$ _____ |
| <input type="checkbox"/> | Condenser Option 2 | Price \$ _____ |
| <input type="checkbox"/> | Furnace Option 2 | Price \$ _____ |
| <input type="checkbox"/> | Condenser Option 3 | Price \$ _____ |
| <input type="checkbox"/> | Furnace Option 3 | Price \$ _____ |
| <input type="checkbox"/> | Coil Model | Price \$ _____ |
| <input type="checkbox"/> | Aprilaire Humidifier Model # | Price \$ _____ |
| <input checked="" type="checkbox"/> | <u>ICE MAKERS (2)</u>
<small>Air Cleaner</small> | <u>SERVICE ONCE A YEAR (CLEANING)</u> Price \$ <u>1,110.00</u> |
| <input checked="" type="checkbox"/> | Other | <u>REPLACE 3-6" VENT STACKS</u> Price \$ <u>2,612.50</u> |

Installation shall include:

SERVICE CALL \$170.00 AN HOUR PLUS MATERIAL

- | | | |
|---|---|---|
| <input type="checkbox"/> New A/C Disconnect
<input type="checkbox"/> New Electrical Whip
<input type="checkbox"/> New Equipment Pad
<input type="checkbox"/> New Vibration Isolation Pads
<input type="checkbox"/> New Refrigerant Lines
<input type="checkbox"/> Evacuate Refrigerant System
<input type="checkbox"/> Charge to Manufacturer's Specs
<input type="checkbox"/> Install Thermostat Model
<input type="checkbox"/> Clean Work Area
<input type="checkbox"/> Reuse Coil | <input type="checkbox"/> New Cased Coil
<input type="checkbox"/> New Coil
<input type="checkbox"/> New Furnace
<input type="checkbox"/> New Condenser
<input type="checkbox"/> Remove Existing Equipment From Premises
<input type="checkbox"/> Plenum Transition
<input type="checkbox"/> _____ New Supply Diffuser(s)
<input type="checkbox"/> New Duct Run from _____ to _____
<input type="checkbox"/> Provide for External Combustion Air
<input type="checkbox"/> New Gas Piping from _____ to _____ | <input type="checkbox"/> New Vent Pipe & Cap
<input type="checkbox"/> New Condensate Pump
<input type="checkbox"/> Install Aux. Condensate Drain Pan
<input type="checkbox"/> Complete System Start Up
<input type="checkbox"/> _____ Year Parts Warranty
<input type="checkbox"/> _____ Year Labor Warranty
<input type="checkbox"/> _____ Year Compressor Warranty
<input type="checkbox"/> _____ Year Heat Exchanger Warranty |
|---|---|---|

Rebates or Specials:

Proposal good for 30 days.
 TERMS: 25% down payment due upon acceptance,
 remaining balance due upon completion of work.

\$ ICE MAKERS Total Option 1 \$ 1,110.00 w/rebates
\$ VENT STACKS Total Option 2 \$ 2,612.50 w/rebates
 \$ _____ Total Option 3 \$ _____ w/rebates

By: _____
 Acceptance (Customer)

Date: _____

By: _____
 Approval (Wiesbrook Sheet Metal Representative)

Date: 6/28/23



Airco Heating & Cooling, LLC

DuPage Township
241 Canterbury Lane
Bolingbrook, IL 60440

☎ (815) 302 4898

ESTIMATE	#10768
SERVICE DATE	Jul 12, 2023
TOTAL	\$5,650.00

CONTACT US

1112 W. Boughton Rd., Unit, 183
Bolingbrook, IL 60440

☎ (630) 679 9009

✉ AircoHeatCool@gmail.com

ESTIMATE

Materials	qty	unit price	amount
Rooftop Flue Stack Replacement Replace rooftop flue stack using galvanized BVent, including rain cap and flashing. We will install, secure and seal flashing to roof.	10.0	\$565.00	\$5,650.00

Materials subtotal: \$5,650.00

Total **\$5,650.00**

Thank you for your patronage, and remember...

"Your Comfort is our Business"

PROPOSAL AND AGREEMENT

Name DUPAGE TOWNSHIP Date 6/28/23
 Street Address 241 CANTERBURY City BOILING BROOK Zip Code _____
 Email Address _____ Phone # _____ Alt # _____

We will furnish and install the equipment listed below at the price, terms and conditions outlined below.

Equipment Specifications

- | | | | |
|-------------------------------------|--|-------|--------------------|
| <input type="checkbox"/> | Condenser Option 1 | Price | \$ _____ |
| <input type="checkbox"/> | Furnace Option 1 | Price | \$ _____ |
| <input type="checkbox"/> | Condenser Option 2 | Price | \$ _____ |
| <input type="checkbox"/> | Furnace Option 2 | Price | \$ _____ |
| <input type="checkbox"/> | Condenser Option 3 | Price | \$ _____ |
| <input type="checkbox"/> | Furnace Option 3 | Price | \$ _____ |
| <input type="checkbox"/> | Coil Model | Price | \$ _____ |
| <input type="checkbox"/> | Aprilaire Humidifier Model # | Price | \$ _____ |
| <input checked="" type="checkbox"/> | Air Cleaner ICE MAKERS (2) | Price | \$ <u>1,110.00</u> |
| <input checked="" type="checkbox"/> | Other | Price | \$ <u>2,612.50</u> |

Installation shall include:

SERVICE CALL \$170.00 AN HOUR PLUS MATERIAL

- | | | |
|---|---|---|
| <input type="checkbox"/> New A/C Disconnect
<input type="checkbox"/> New Electrical Whip
<input type="checkbox"/> New Equipment Pad
<input type="checkbox"/> New Vibration Isolation Pads
<input type="checkbox"/> New Refrigerant Lines
<input type="checkbox"/> Evacuate Refrigerant System
<input type="checkbox"/> Charge to Manufacturer's Specs
<input type="checkbox"/> Install Thermostat Model
<input type="checkbox"/> Clean Work Area
<input type="checkbox"/> Reuse Coil | <input type="checkbox"/> New Cased Coil
<input type="checkbox"/> New Coil
<input type="checkbox"/> New Furnace
<input type="checkbox"/> New Condenser
<input type="checkbox"/> Remove Existing Equipment From Premises
<input type="checkbox"/> Plenum Transition
<input type="checkbox"/> _____ New Supply Diffuser(s)
<input type="checkbox"/> New Duct Run from _____ to _____
<input type="checkbox"/> Provide for External Combustion Air
<input type="checkbox"/> New Gas Piping from _____ to _____ | <input type="checkbox"/> New Vent Pipe & Cap
<input type="checkbox"/> New Condensate Pump
<input type="checkbox"/> Install Aux. Condensate Drain Pan
<input type="checkbox"/> Complete System Start Up
<input type="checkbox"/> _____ Year Parts Warranty
<input type="checkbox"/> _____ Year Labor Warranty
<input type="checkbox"/> _____ Year Compressor Warranty
<input type="checkbox"/> _____ Year Heat Exchanger Warranty
<input type="checkbox"/> _____
<input type="checkbox"/> _____ |
|---|---|---|

Rebates or Specials:

Proposal good for 30 days.
 TERMS: 25% down payment due upon acceptance,
 remaining balance due upon completion of work.

<u>\$ ICE MAKERS</u>	Total Option 1	\$ <u>1,110.00</u>	w/rebates
<u>\$ VENT STACKS</u>	Total Option 2	\$ <u>2,612.50</u>	w/rebates
\$ _____	Total Option 3	\$ _____	w/rebates

By: _____
Acceptance (Customer)

Date: _____

By: _____
Approval (Wiesbrook Sheet Metal Representative)

Date: 6/28/23

KREEM
HEATING & COOLING, INC.
 EPA CERTIFIED & INSURED
 KREEMHVAC@GMAIL.COM
 MAJID ALI (630) 442-3034

JOB PROPOSAL: Price Valid for 5 Days

DATE: 07/17/2023

NAME:	Mr, Bob Martin
ADDRESS:	251 Canterbury lane Bolingbrook ,IL 60440
PHONE:	(815) 302-4898

QUAN.	DESCRIPTION	AMOUNT
	Ice maker complete maintenance and services 2 units Cleans all sensors Clean the condenser unit Clean the pan Each ice maker services	\$175.00

TOTAL	\$350.00
--------------	-----------------

KREEM

THANK YOU FOR YOUR BUSINESS!

HEATING & COOLING, INC.
EPA CERTIFIED & INSURED
KREEMHVAC@GMAIL.COM
MAJID ALI (630) 442-3034

Required Payment Details:

50% deposit with signed contract – Remaining 50% due upon completion of Installation.

*Please make all checks payable to **Kreem Heating & Cooling***

Customer: Bob Martin

Signature: _____ Date: _____

Kreem Heating & Cooling Inc. CEO: MAJID ALI

Signature: _____ Date: _____

THANK YOU FOR YOUR BUSINESS!



Courtesy Plumbing & Services, Inc.

751 N Bolingbrook Drive | Link 10 | Bolingbrook, IL 60440
 877-758-6448 | mickey@courtesyplumbingil.com |
 www.plungeit.com

RECIPIENT:

DuPage Township
 Joseph and Sarah Levy Center
 251 Canterbury Lane
 Bolingbrook, Illinois 60440
 Phone: 815-302-4898

Invoice #1231228013

Issued 06/23/2023
 Due 07/23/2023
 Ad Code Repeat Customer
 Technician Glen Ford

Total \$1,435.37

Toilet Repair & Urinal Repairs

PRODUCT / SERVICE	DESCRIPTION	QTY.	UNIT PRICE	TOTAL
-------------------	-------------	------	------------	-------

06/23/2023

Misc. Plumbing Repairs	Service call for gaskets needing replaced	1	\$1,435.37	\$1,435.37*
------------------------	---	---	------------	-------------

We arrived on site and inspected the men's urinal and found that the automatic Sloan flush valve was defective.

We ordered and went to our supply house and we procured a Sloan automatic flush valve. We returned and turned the water off to the urinal and removed the defective Sloan flush valve and installed a new Sloan automatic Optima flush valve. After repair we turned the water back on to the urinal and tested for proper function - Service was restored

We then inspected a toilet in the women's bathroom and found that the gasket on the Sloan valve to the top of the toilet was defective. We turned the water off to the toilet and removed the commercial flush valve and defective valve to toilet spud gasket. We installed a new valve to toilet spud gasket and brass spud and reinstalled the commercial flush valve. We turned the water back on to the toilet and tested the toilet for any further leaks and proper function - Service was restored

Thank you,

Glen



Courtesy Plumbing & Services, Inc.

751 N Bolingbrook Drive | Link 10 | Bolingbrook, IL 60440
 877-758-6448 | mickey@courtesyplumbingil.com |
 www.plungeit.com

Total **\$1,435.37**

* Non-taxable

By allowing the listed work on this invoice to be performed and or paying for the work listed on this invoice the customer agrees that in the event of non-payment or any other breach of the agreement, the customer shall be responsible and pay the cost of collection including court cost, attorneys fees, and interest at a rate of ten percent per annum on the unpaid balance. The customer agrees that by allowing the work listed on this invoice to be performed that they had agreed to have the listed work on the invoice performed via a verbal approval of a verbal quote or a signed approval of a written quote for the listed work on the invoice for the listed cost of work on the invoice. The customer also agrees that the listed work performed on this invoice was done to their satisfaction for the listed cost on this invoice before the technician left the location where the work was performed. By allowing the listed work on this invoice to be performed and or paying for the work the customer also agrees to the below listed terms:

Contractors are required by law to be licensed and regulated by the Illinois Department of Public Health. Any questions concerning a contractor may be referred to the Illinois Department of Public Health.

Under the Illinois Mechanics Lien Law and contractor, subcontractor, laborer, or other person who helps to improve your property, but is not paid for his/her work or supplies, has the right to enforce a claim against your property. This means that after a court hearing, your property could be sold by a court office and proceeds of the sale to satisfy indebtedness. This can happen even if you have paid your contractor in full if the subcontractors, laborers, or suppliers remain unpaid.

To preserve their right to file a claim or lien against your property, certain claimants such as subcontractors or material suppliers are required to provide you with a document entitled "Preliminary Notice". Original (at prime) contracts and laborers for wages do not have to provide this notice. A Preliminary Notice is not a lien against your property, its purpose is to notify you of persons who may have a right to file a lien against your property if they are not paid. (Generally, the maximum time allowed for filing a claim or lien against your property is two years after completion of your project).

TERMS AND CONDITIONS

RESPONSIBILITY OF THE CUSTOMER:

Customer represents that, except as described in the request for service, all plumbing, heating and air conditioning and drain systems are in good repair and condition and agrees to hold Courtesy Plumbing & Services, Inc. harmless of discovery of defective conditions, including but not limited to the following:

- Improper or faulty plumbing
- Lines that are settled or broken
- Deteriorated Flooring
- Rusted or defective pipes
- Existing illegal conditions
- Deteriorated walls
- Acids in the drain system
- Defective roofing



Courtesy Plumbing & Services, Inc.

751 N Bolingbrook Drive | Link 10 | Bolingbrook, IL 60440
877-758-6448 | mickey@courtesyplumbingil.com |
www.plungeit.com

Notes Continued...

RESPONSIBILITIES OF COURTESY PLUMBING & SERVICES, INC. - CONDITIONS AND LIMITATIONS

Courtesy Plumbing & Services, Inc. shall do all work in a competent, workmanlike manner. Courtesy Plumbing & Services, Inc. is not responsible for any illegal conditions.

LIMITED WARRANTY

Courtesy Plumbing & Services, Inc. warrants all work to be free from defects in material and workmanship of the warranty period of nine (90) days from completion unless otherwise stated in writing on the face hereof. All drain stoppages are warranted for a period of thirty (30) days from the completion unless otherwise stated in writing on the face hereof. All warranties are void if payment is not made when due. Warranties extend only to the customer and are not transferrable. If a defect in materials or workmanship covered by this warranty occurs, Courtesy Plumbing & Services, Inc. will, with reasonable promptness, during normal business hours, Monday through Friday 8am-4pm, remedy the defect. In no event shall Courtesy Plumbing & Services, Inc. be held liable for water or other damage caused by any delay in remedying a defect. To obtain warranty performance notice, Courtesy Plumbing & Services, Inc. of any defect or claims for breach at the address and telephone number on the face hereof or telephone corporate headquarters at 877-758-6448.

EXCLUSIONS AND LIMITATIONS: CUSTOMER'S RIGHT TO REPAIR AND REPLACEMENT ARE THE EXCLUSIVE REMEDIES AND COMPANY SHALL NOT BE LIABLE FOR INCIDENTAL OR CONSEQUENTIAL DAMAGES RESULTING FROM THE MATERIALS PROVIDED FOR IN THIS CONTRACT.

Courtesy Plumbing & Services, Inc. is not responsible for the following which are excluded from the coverage of this limited warranty:

1. Defective conditions listed under the above "Responsibilities of Customer"
2. Work performed by or materials installed by others not in this agreement
3. Defects and failures from mistreatment or neglect

This limited warranty is the only express warranty Courtesy Plumbing & Services, Inc. gives. IMPLIED WARRANTIES, including, but not limited to warranties of merchantability and fitness for a particular purpose, are limited to a duration of ninety (90) days from the date of completion.

PROTECTION OF CUSTOMER'S PROPERTY

Customer agrees to remove or protect any personal property, inside and out, including, but not limited to carpets, rugs, shrubs and planting. Courtesy Plumbing & Services, Inc. shall not be responsible for said items. Nor shall Courtesy Plumbing & Services, Inc. be held responsible for the natural consequences of Courtesy Plumbing & Services, Inc. work which may cause damage to improvements to real property including, but not limited to, curbs, sidewalks, walks, driveways, garages, patios, lawns, shrubs, trees, flower beds, sprinkler systems, wallpaper, drywall, stucco, tile, cabinets, and other appurtenances to the residence or other real property. Not responsible for removal of any excess dirt or spoils.

Courtesy Plumbing & Services, Inc. shall not be held responsible for damage to personal property, real property, or any improvements to real property caused by persons delivering materials or equipment or keeping gates and doors closed for children and/or animals.

ENTIRE AGREEMENT

This is the entire agreement. The parties are not bound by any oral expression or representation by any agent purporting to act for, or on their behalf, or by any commitment, or arrangement not to set forth herein. The agreement binds jointly and severally all signing as Customer, their heirs, representatives, successors and assigns.

Courtesy Plumbing & Services, Inc. will not provide an itemized breakdown of materials and labor for flat rate priced book. However, Courtesy Plumbing & Services, Inc. will provide an itemized list of all materials used to perform the necessary repair upon request.

Thank you,



Courtesy Plumbing & Services, Inc.

751 N Bolingbrook Drive | Link 10 | Bolingbrook, IL 60440
877-758-6448 | mickey@courtesyplumbingil.com |
www.plungeit.com

Notes Continued...

Courtesy Plumbing & Services, Inc.